

30% Higher Productivity GUARANTEED!

**When used with machine
tools up to 15 kw (20 hp)**

• **Double Compression Filter Hold Down** (Patent US 2006/0278572 A1). ChipBLASTER has created the most efficient bag filtration on the market today. Our double compression filter hold down lid protects both our system and the machine tool from contamination.

• **ChipBLASTER's Super Duty Pump** (Patent 6,776,419) is designed for coolant. It is durable enough that we offer an optional 2, 3, 4, or 5 year warranty.

• **Simple Low Cost Installation Kits**
Installation kits allow "plug and play" installation. Engineered packages are available for most machine tools. Please contact ChipBLASTER for details.

• **A Full Range of Safety Features**
Safety Features insures a safe machining process without damage to the machine tool, the part, or tooling. We can meet or exceed all international requirements for operator and machine tool protection with integrated automatic overload protection as well as many alarm circuits.



ISO 9001



ISO 14001

Model J-30

30 liters per minute
(8 gpm)

Pressure to 80 bar
(1200 psi)

- Small footprint
- Less foaming
- Lower temperature

AVAILABLE with

Chip **CHILLER**

High Performance Chillers by ChipBLASTER

**34,000 BTU Built in coolant
CHILLER!**

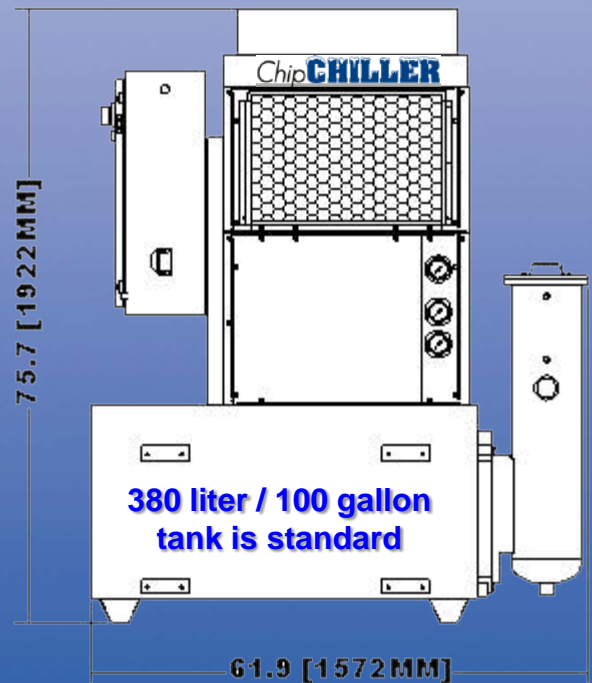

J-30 STANDARD CONFIGURATION

The ChipBLASTER J-30 is fed by a transfer pump that draws from the machine tool sump, through the filter vessel to the integral 380 liter (100 gal) tank. When the machine tool calls for coolant, the filter pump(s) draws the coolant from the ChipBLASTER tank and pumps through the post (safety) filter to the inlet of the positive displacement pump. The coolant then flows at high pressure through a series of distribution and safety valves and on to the machine tool.

M Code Requirement:

1 "M" code controlled signal is required for activation/deactivation of the ChipBLASTER.
A 24 VDC, 110 VAC or 240 VAC signal is acceptable.

•Latching "M" codes are standard, If your machine uses pulsed "M" codes, please contact ChipBLASTER

Required Electrical Power:

28 amps, 230 VAC, 3 Phase, 60 Hz
14 amps, 460 VAC, 3 Phase, 60 Hz
18 amps, 400 VAC, 3 Phase, 50 Hz

For machine tools up to 15 kw (20 hp)

Options Available With Your ChipBLASTER:

Top mounted **ChipCHILLER**

ChipBLASTER offers a 34,000 BTU (10kw) top mount coolant chiller unit. Totally integrated into the ChipBLASTER, with one installation, one connection and NO ADDITIONAL FLOOR SPACE!

Extended Warranty

2, 3, 4, and 5 year parts warranty for your ChipBLASTER is available. (Your unit has a standard 1 year parts and labor warranty)

Dual Filters

Allows filter changes "in-process" eliminating machine tool down time.

Operator Wash Down Wand

This will supply 2 bar (30 psi) of fluid for the machine wash down.

Available with CE, CSA Certification

ChipBLASTER[®]

The World's Best High Pressure Coolant Systems

13605 S. Mosiertown Road

Meadville, PA 16335 USA

Phone: +1 (814) 724-6278

Fax: +1 (814) 724 6287

www.chipblaster.com

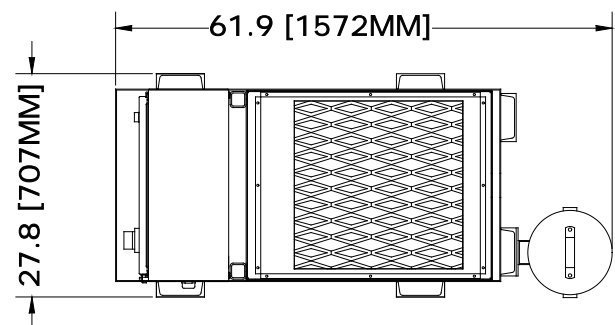

Shown with optional

ChipCHILLER